



Killion floral displays feature the very best!

Preservation:

Killion floral merchandisers will preserve your floral products and greatly reduce shrink.

Presentation:

Our Beautiful and unique designs will present your items in such a way to greatly increase sales.

Performance:

From energy conservation, to durability Killion floral merchandisers are designed to be the very best.

&

Price:

State of the art manufacturing facilities and lean production techniques allow us to bring you very attractive pricing.

For more information, just give us a call or visit our web site.

www.killionindustries.com

800-421-5352





Traditions

Offer value and outstanding floral merchandising.

Traditional Beauty and Performance In our upright floral merchandisers!

State of the art design allows the customer to see more floral product and less display case. This concept with years of in store testing has proven to greatly increase sales.

Low open front with optional side windows or mirrors shows off the natural beauty of the flowers and promotes impulse buying.

Front and optional side bumpers also help protect the entire case from impact damage.



Traditions CFFM70-35



Traditions CFFM48-35

- * Oversize evaporator coils and low velocity fans are especially designed for floral preservation. This system greatly reduces shrink and prevents products from having to be marked down.
- * Standard vase racks can be adjusted or turned into shelves for arrangements.
- * Quite top mount compressor system is easy to service and clean and allows for zero clearance on all sides.
- * 5 full rows of vases can be used for a true Wall of Flowers design.



Specifications:

Model	Width	Height	Depth	Ship (lbs)	Unit HP	Electrical	Amps
CFFM36-35	36"	84.25	35"	750	3/4	115 or 208	30 / 20
CFFM45-35	45"	84.25	35"	800	3/4	115 or 208	30 / 20
CFFM48-35	48"	84.25	35"	845	1	115 or 208	30 / 20
CFFM51-35	51"	84.25	35"	850	1	115 or 208	30 / 20
CFFM70-35	70"	84.25	35"	1000	1	208	(2) 20
CFFM94-35	94"	84.25	35"	1200	(2) 1	115 or 208	(2) 30 / (2) 20

Other Lengths available please call for more info: Special depth cases (23" & 42") are also available:

Above specifications are for Self Contained systems; Remote systems are available

Note: All sizes are nominal and subject to change without notice; please confirm before ordering:

The is designed for use in air conditioned areas having a maximum temperature of 75°F or maximum relative humidity of 50%.

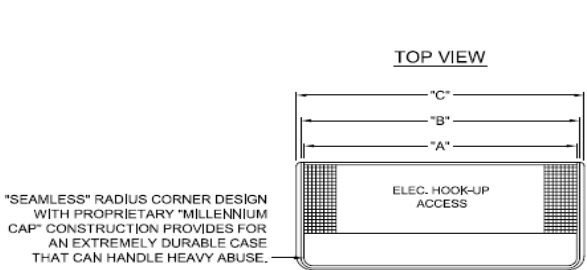

NAME	"A"	"B"	"C"	"D"
CFFM-36-35	34-1/4"	35-3/4"	38"	35"
CFFM-48-35	46-1/4"	47-3/4"	50"	35"
CFFM-70-35	68"	69-1/2"	71-3/4"	35"
CFFM-94-35	92"	93-1/2"	95-3/4"	35"
CFFM-36-42	34-1/4"	35-3/4"	38"	42"
CFFM-48-42	46-1/4"	47-3/4"	50"	42"
CFFM-70-42	68"	69-1/2"	71-3/4"	42"
CFFM-94-42	92"	93-1/2"	95-3/4"	42"

"A" = INSIDE DIMENSION "B" = OUTSIDE DIMENSION
"C" = WITH BUMPER "D" = OUTSIDE DIMENSION

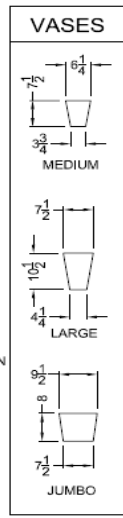
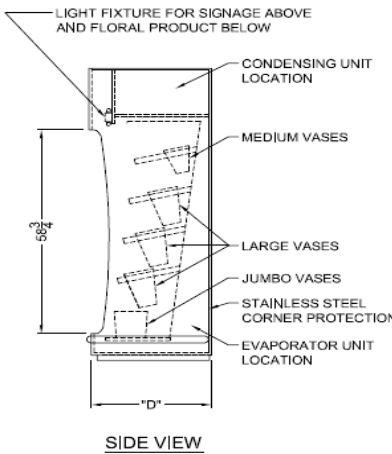
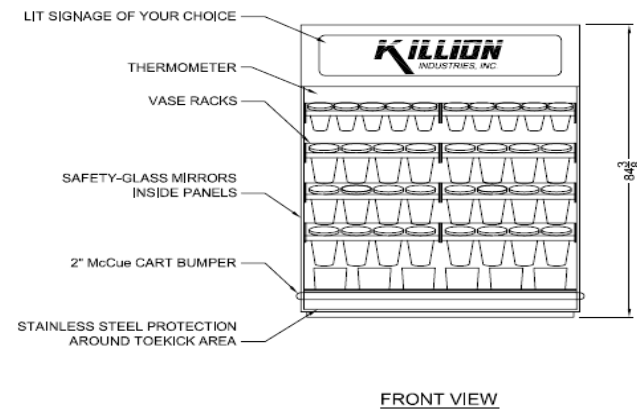



Low-Pro

Offers a counter height display with outstanding floral presentation.

Low Profile Presentation with state of the art performance.

Our special low profile design allows the customer to see more floral product and less display case. This concept with years of in store testing has proven to greatly increase sales.

Clear front and side windows allow product to be clearly seen and promotes impulse buying.

Casters and inset base allows zero clearance applications and protects the mechanical section from shopping cart and floor buffer damage.

Front and optional side bumpers also help protect the entire case from impact damage



Oversize evaporator coils and low velocity fans are especially designed for floral preservation. This system greatly reduces shrink and prevents products from having to be marked down.

The new 6' Low Profile self-contained floral display is mounted on casters with side windows and optional over head lighting.

The display is available in either the easy to clean sloped deck interior with dual refrigeration air-flows or for the ultimate in floral flexibility our special racking system with air curtain air flows.



6' Counter High FSSC 72-42-50 shown with grower bucket inserts.



The Interior molded fiberglass drip pan and heavy duty condensate system is designed to handle high humidity conditions and helps prevent the dreaded water on the floor dangers.

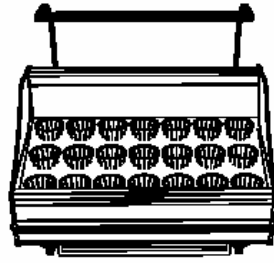
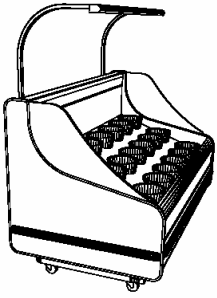

Available in different lengths, colors and refrigeration systems, including remote and self-contained. Please call for details:

Model	Width	Height	Depth	Ship (lbs)	Unit HP	Electrical	Amps
FSSC 72-42-50	72"	50"	42"	650	1	208	30
<i>Above specifications are for Self Contained systems:</i>							
<i>Note: All sizes are nominal and subject to change without notice; please confirm before ordering:</i>							

ISO VIEW

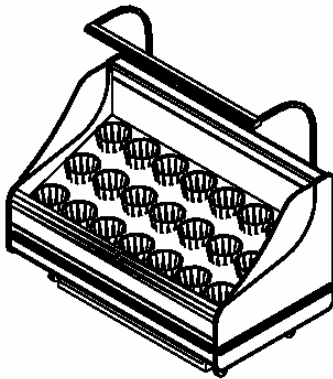

TOP VIEW

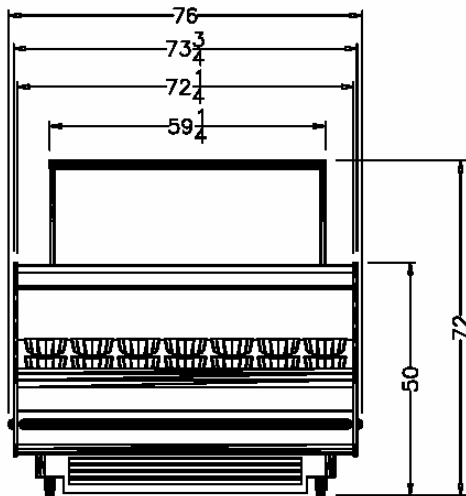
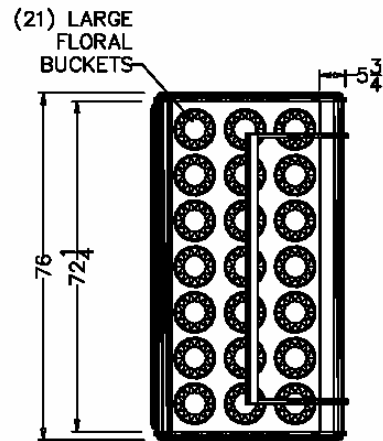

FRONT VIEW

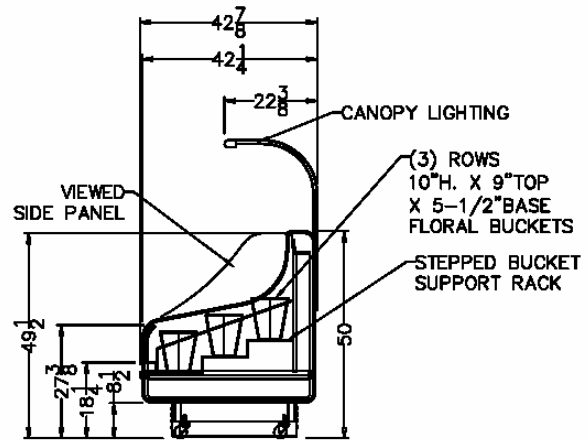

SIDE VIEW



Top Combo's

Offer the best in over & under floral merchandising.

The best of both worlds is the combination case. The open section for the high volume impulse sales and the closed section for the especially sensitive floral specialties and arrangements.

Clear front, sides and top wrap around end windows allow product to be seen clearly and greatly promotes impulse buying.

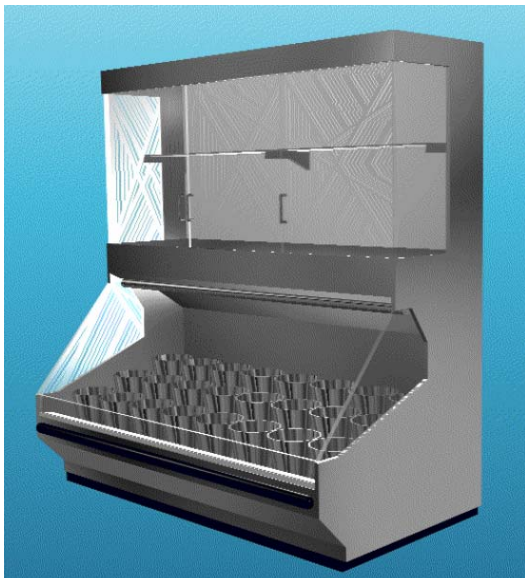

Top Combo Case: DCFM-74-42-81-V Shown



- * High intensity low temperature lighting shows product in its best colors.
- * For the ultimate in floral preservation the dual (one for top and bottom) oversized evaporator coils and low velocity fans are specifically designed to keep case humidity high.
- * While allowing for outstanding temperature control, our unique air circulation system also removes the ethylene gas from the top closed section of the cooler.
- * Self-contained top mount or remote refrigeration systems are available.
- * Heavy duty all metal construction with bumper helps protect the case from floor buffer and shopping cart damage.

Specifications shown for 6 foot remote display: For other configurations please call

Refrigeration Specifications (Remote)		Electrical Specifications	
Model # DCFFM-74-42-81-V	6' Floral Combo Case	Volts	115
Btu/h	7,650	Phase	1
Saturated Evaporator Temp. (°F)	22	Hz	60
Refrigerant (others available)	507	Total Amps	2.5
Defrosts/Day	2	Maximum Fuse	20

TOP VIEW

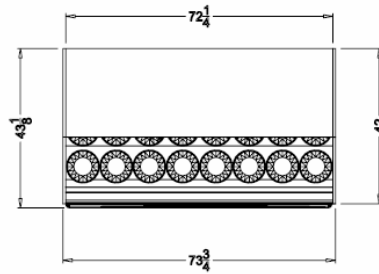

ISOMETRIC VIEW

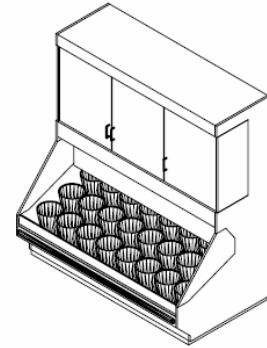

Top Combo's come in different lengths; They are available in self contained or remote refrigeration systems.

Many varieties of colors and options are also available.

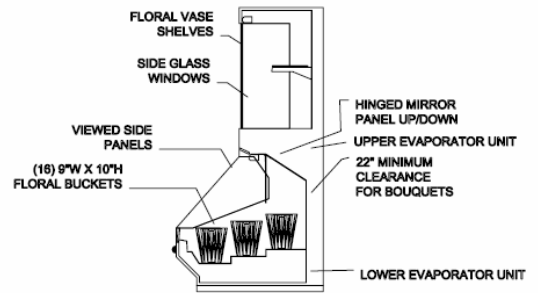
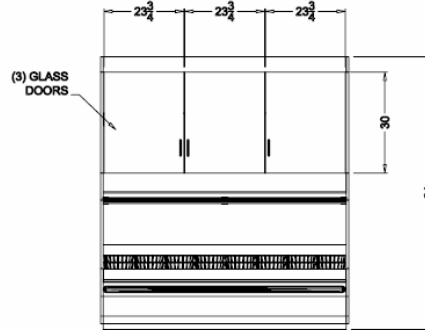

ALL DIMENSIONS ARE NOMINAL



Space a problem? Need a great self contained combo case? On a tight budget, but need a case that treats flowers with care? Then please consider our SL-FFM-48-35-84. You will be glad that you did.

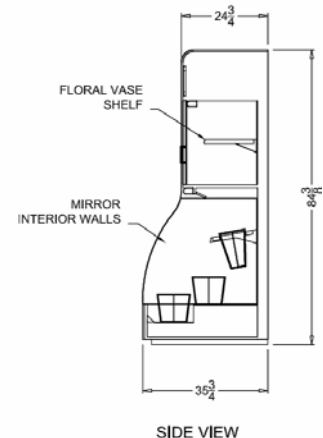
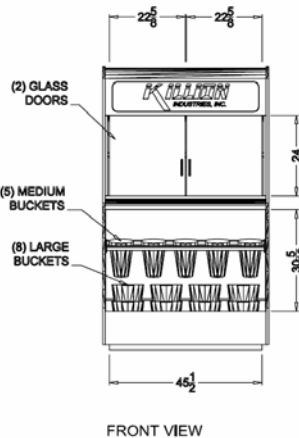



3-D's

Offers three sided merchandising with outstanding floral preservation.

Three sided Presentation with state of the art performance.

This display is especially designed to handle the harsh conditions that are normally found in wholesale clubs or mass merchandiser type environments. Killion's new 3 D case takes abuse with ease and will stay looking and performing great for years.

Please take a moment to see all our features. You will be impressed by how well build and how much this case can compliment your stores floral needs.



Special Features Include:

Construction:

- * 3 HP heavy duty top mounted compressor system.
- * Dual cascading condensate evaporator pans for High humidity conditions.
- * Heavy duty steel base and bumper is almost impervious to fork lifts, carts and floor buffers.
- * Steel channels under the unit allow for easy use of fork lift or pallet jack to install, move or relocate display.

Performance:

- * Special low velocity air curtain technology is used to keep flowers and water cold.
- * Customized evaporator coils are utilized to keep humidity high and reduce floral dehydration.

Merchandising:

- * Adjustable heavy duty shelving can handle even grower buckets full of water.
- * Interchangeable back lighted signs:
- * Price tag moldings on each set of shelves.
- * Three sided dual over head lighting:





Interchangeable lighted signs can be used to promote special seasons, like Mothers day, Easter & Valentines day!



Super thick steel base with heavy duty bumper protects case from, fork lifts, carts, and floor cleaning equipment.



Dual Cascading condensate evaporator pans help in high humidity conditions.

Model	Width	Height	Depth	Ship (lbs)	Unit HP	Electrical	Amps
CFFM 94-40-99	94"	99"	42"	1600	3	208	60
Above specifications are for Self Contained systems:							
<i>Note: All sizes are nominal and subject to change without notice; please confirm before ordering:</i>							

Available in different lengths, colors and refrigeration systems, including remote and self-contained. Please call for details:

TOP VIEW

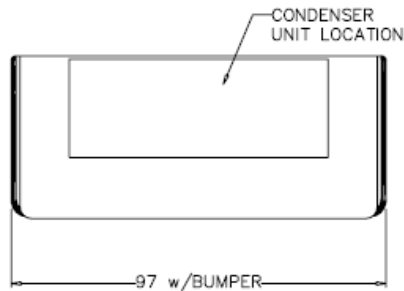

PERSPECTIVE VIEW



Note: Display shown with Growers buckets, but can be configured for many different size and shaped vases including Procona. Also the racking can be adjusted to become shelves for arrangements:

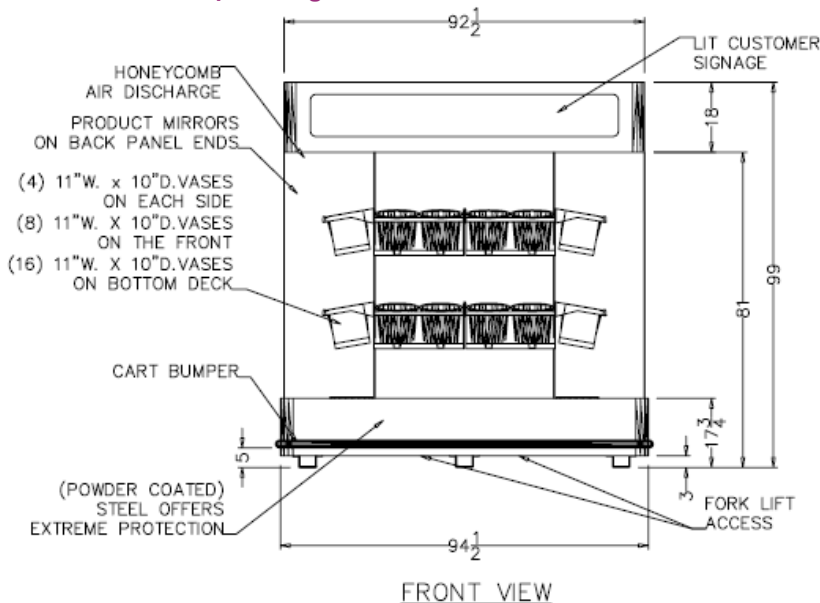

FRONT VIEW

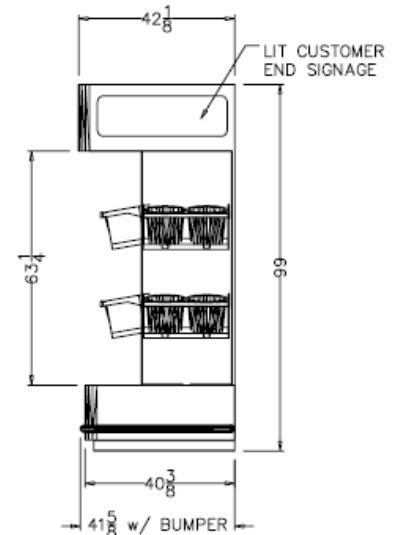

SIDE VIEW



**New redesign
Coming Soon!**

Wall of Flowers

Offers open air presentation with superior refrigeration.

Killion's New wall of flowers offers you the best of both worlds. The best of product display without the top interfering with the presentation of the product but with the superior refrigeration of the standard upright display.

Now you can have outstanding presentation without sacrificing preservation of the flowers. The end result is increased sales and reduced shrink. Add this to our new aggressive pricing programs you will see that Killion offers more than anyone else in presentation, preservation, performance and price.

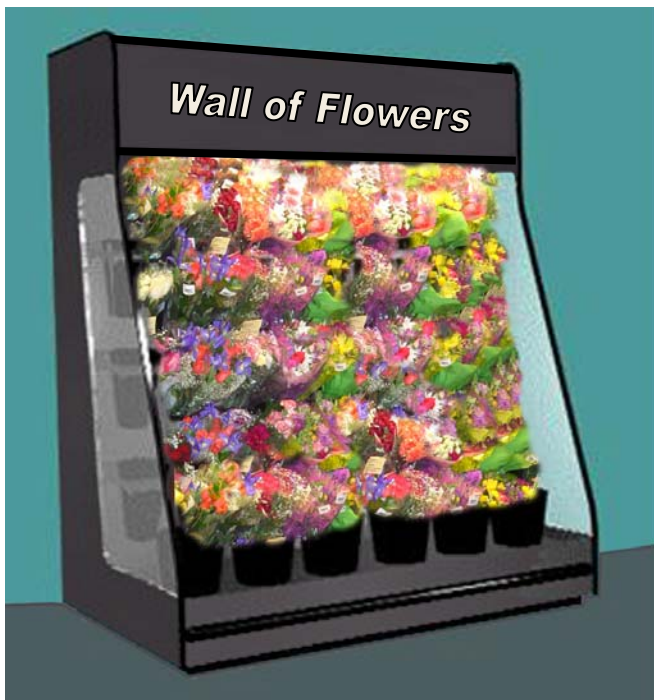

6 Foot display shown, 4', 6', & 8' displays available.
Different finishes and colors available on request

“Seven” Major reasons that our new wall of flowers out performs the competition.

1. True high tech refrigeration performance, keeps flowers up to 30% colder than the competition (See Blue line for airflow, Flowers are directly cooled and protected from the warm air in the store)
2. Flowers lower in the cooler allows ease of shopping for all rows. The top row can be easily reached by just about everyone.
3. Overhead lighting is standard with special goose neck lighting available for the lower rows as an option.
4. Top mount compressor system keeps dirt out of the condenser coils and allows case to be serviced without disrupting the product or moving the display.
5. Lighted removable sign allows for seasonal changes of graphics. This helps promote special sales for Easter, Valentine's Day and other important holidays.
6. Cost of operation, because our systems are easy to service and our airflows are more protected not only is maintenance cost reduced but energy costs are lowered as well.
7. Initial cost, is very attractive and your return on investment will be far faster with our display.

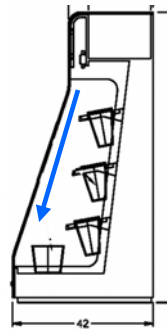



Model	Width	Height	Depth	Ship (lbs)	Unit HP	Electrical	Amps
CFFM 70-42-84	70"	84"	42"	700	1	208 / 1ph	30
Above specifications are for Self Contained systems:							
<i>Note: All sizes are nominal and subject to change without notice; please confirm before ordering:</i>							

Available in different lengths, colors and refrigeration systems, including remote and self-contained. Please call for details:



Traditional upright cooler with Wall of flowers racking insert shown.

The Same racking is used in the Wall of flowers but the top does not interfere with the upper row of flowers.



TOP VIEW

ISOMETRIC VIEW

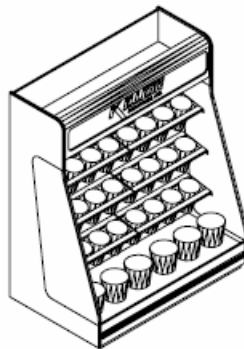
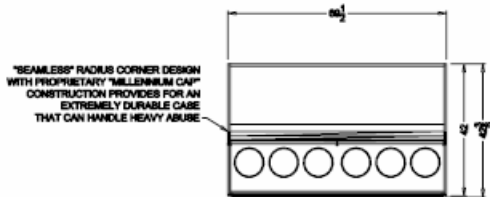

PERSPECTIVE VIEW

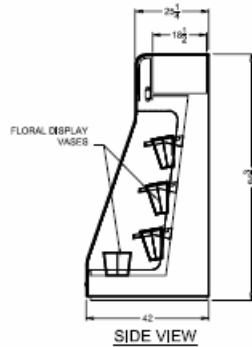
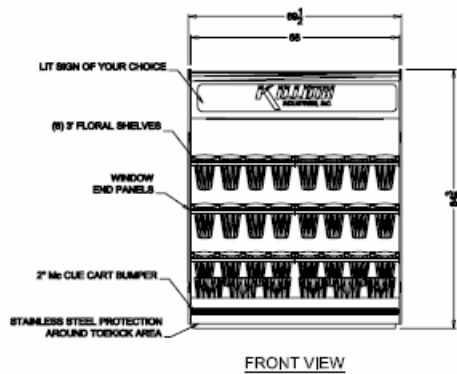
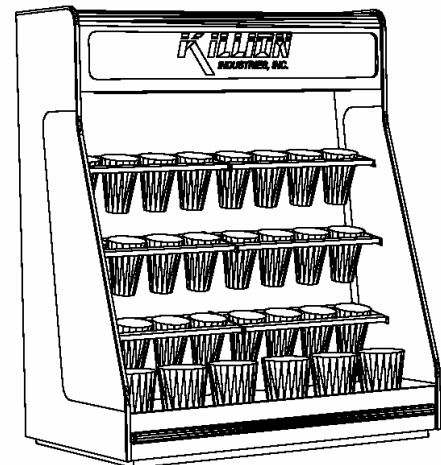



Special order only

Island Spot Merchandising at its best!



Each and every Killion floral display is designed from the ground up to be a floral cooler.

Great care has been taken to insure that every display will provide you with the best in presentation, preservation and durability. With beautiful designs and the latest in refrigeration technologies you will find that Killion displays are a wonderful choice for your floral department.



The latest in large Island displays. This unit is design to bring cold air down from the top to help preserve and keep the fresh look of the flowers. Add that with chilled water and you have one of the best spot displays ever.

To help enhance the natural beauty of the flowers we provide canopy lighting.

For Maximum flexibility this display is self contained and does not require a drain. (remote optional)

Available in many different finishes, we can match or compliment any store décor:

Double bumpers and heavy duty construction help keep the display looking new for years to come.